

Requested Patent: WO03057103A1  
Title: HYDROCOLLOID BANDAGE ;  
Abstracted Patent: WO03057103 ;  
Publication Date: 2003-07-17 ;  
Inventor(s): DING JIAN LING (US) ;  
Applicant(s): SCAPA NORTH AMERICA (US); DING JIAN LING (US) ;  
Application Number: WO2002US41745 20021231 ;  
Priority Number(s): US20020345796P 20020102 ;  
IPC Classification: A61F13/02; A61L15/22; A61L15/60 ;  
Equivalents: ;

**ABSTRACT:**

A hydrocolloid bandage for the wound care designed for improved pliability and decreased peripheral edge lift. In particular, the invention is concerned with a hydrocolloid bandage which is absorbent, non-damaging to the skin and comfortable to the user preferably having at least a hydrocolloid region covered by film and adhesive layers which contact the user's skin at the periphery of the bandage.

(19) World Intellectual Property Organization  
International Bureau



(43) International Publication Date  
17 July 2003 (17.07.2003)

PCT

(10) International Publication Number  
WO 03/057103 A1

(51) International Patent Classification: A61F 13/02, A61L 15/22, 15/60

(74) Agents: NASSIF, Claude et al.; Greenberg Traurig LLP, 2450 Colorado Avenue, Suite 400E, Santa Monica, CA 90404 (US).

(21) International Application Number: PCT/US02/41745

(81) Designated States (national): AE, AG, AL, AM, AT, AU, AZ, BA, BB, BG, BR, BY, BZ, CA, CH, CN, CO, CR, CU, CZ, DE, DK, DM, DZ, EC, EE, ES, FI, GB, GD, GE, GH, GM, HR, HU, ID, IL, IN, IS, JP, KE, KG, KP, KR, KZ, LC, LK, LR, LS, LT, LU, LV, MA, MD, MG, MK, MN, MW, MX, MZ, NO, NZ, OM, PH, PL, PT, RO, RU, SD, SE, SG, SK, SL, TJ, TM, TN, TR, TT, TZ, UA, UG, US, UZ, VN, YU, ZA, ZM, ZW.

(22) International Filing Date: 31 December 2002 (31.12.2002)

(25) Filing Language: English

(26) Publication Language: English

(30) Priority Data: 60/345,796 2 January 2002 (02.01.2002) US

(84) Designated States (regional): ARIPO patent (GH, GM, KE, LS, MW, MZ, SD, SL, SZ, TZ, UG, ZM, ZW), Eurasian patent (AM, AZ, BY, KG, KZ, MD, RU, TJ, TM), European patent (AT, BE, BG, CH, CY, CZ, DE, DK, EE, ES, FI, FR, GB, GR, IE, IT, LU, MC, NL, PT, SE, SI, SK, TR), OAPI patent (BF, BJ, CF, CG, CI, CM, GA, GN, GQ, GW, ML, MR, NE, SN, TD, TG).

(71) Applicant (for all designated States except US): SCAPA NORTH AMERICA [US/US]; 111 Great Pond Drive, Windsor, CT 06095 (US).

(72) Inventor; and

(75) Inventor/Applicant (for US only): DING, Jian, Ling [US/US]; 78 Chase Hollow Lane, Glastonbury, CT 06033 (US).

Published: with international search report

[Continued on next page]

(54) Title: HYDROCOLLOID BANDAGE

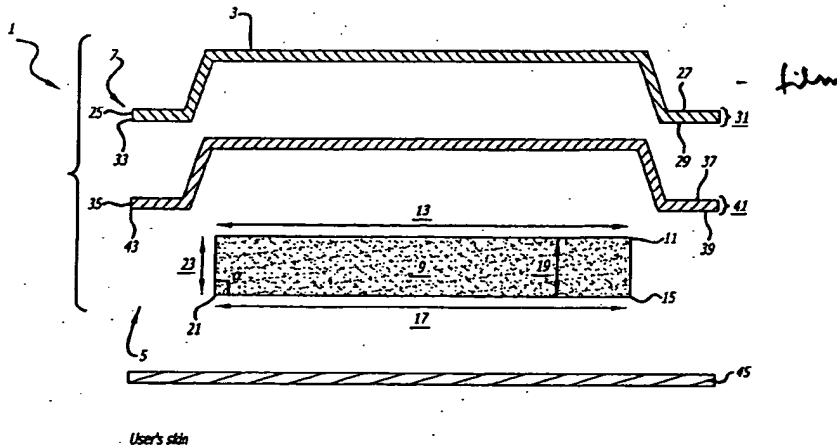

hydrocolloid region

WO 03/057103 A1

(57) Abstract: A hydrocolloid bandage for the wound care designed for improved pliability and decreased peripheral edge lift. In particular, the invention is concerned with a hydrocolloid bandage which is absorbent, non-damaging to the skin and comfortable to the user preferably having at least a hydrocolloid region covered by film and adhesive layers which contact the user's skin at the periphery of the bandage.



— before the expiration of the time limit for amending the claims and to be republished in the event of receipt of amendments

For two-letter codes and other abbreviations, refer to the "Guidance Notes on Codes and Abbreviations" appearing at the beginning of each regular issue of the PCT Gazette.

## HYDROCOLLOID BANDAGE

### BACKGROUND OF THE INVENTION

[0001] This invention relates to a hydrocolloid bandage for use in wound care. In particular, the invention is concerned with a hydrocolloid bandage which is absorbent, non-damaging to the skin and comfortable to the user. Further, the invention is concerned with a bandage that is pliable and able to contour to the skin of the user and offers good adhesion to skin so that the hydrocolloid bandage does not lift from the skin during use.

[0002] Wound care is desirable to improve the health and appearance of underlying dermal tissues. Wounds, either injury induced, such as cuts, abrasions or blisters, or surgically induced, such as surgical incisions or ostomies, for example, require localized treatment to remedy the affected area and to prevent further dermal damage. If wounds are not properly treated, further dermal irritation can occur resulting in secondary infections and further discomfort to the patient.

[0003] Recently, the use of hydrocolloid bandages has spread beyond just the hospital setting and are now commonly found at the retail level for general consumer use. Although hydrocolloid bandages are more expensive than traditional bandages, their expense is justified by their improved utility for wound care. For example, hydrocolloid bandages 1) absorb moisture and wound extrudate, maintaining a moist environment and promoting wound healing; 2) remove excess liquid and perspiration from the skin surface to prevent maceration that can compromise the integrity of skin; 3) provide mild bonds to skin, which avoids physical irritation to skin upon dressing removal; 4) offers a long term wearing such as days, even a week.

[0004] However, there are limitations of the current hydrocolloid bandages when they are worn for a long period of time. A thick bandage profile makes it less conformable, and body movement can cause debonding and channeling of the bandage. The stress applied to the bandage dressing edge during a long term wearing can also cause edge lifting and/or channeling type of debonding from skin, which lead to adhesion failure. Also, the rubber PSA ingredients in the hydrocolloid matrix is prone to cold flow (flow at room temperature). The sticky adhesive tends to flow out of the bandage periphery, and cause sticky edges. Such sticky edges then catch clothes, bed sheets, etc. and cause edge lifting of the bandage.

[0005] Therefore, there is a need for a hydrocolloid dressing which provides good absorbency and/or good structural integrity, enhanced patient comfort and better adhesion to skin.

Further, there needs to be a more conformable bandage with improved peripheral adhesion to skin, and decreased tendency to cold flow.

### SUMMARY OF THE INVENTION

[0006] The invention provides a hydrocolloid bandage which has improved advantages over known hydrocolloid dressings. The hydrocolloid bandages provide enhanced absorbency, enhanced structural integrity and enhanced adhesion to the wound site and patient comfort.

[0007] According to the invention, there is provided a hydrocolloid bandage (bandage) for wound care having an upper surface area and a lower surface area for adhering to the epidermis, dermis or wound area (skin) of the user.

[0008] The bandage preferably comprises a hydrocolloid region covered by a flexible film layer (film). Further, the bandage preferably includes a continuous or discontinuous adhesive layer. Optionally, a release liner can be applied to the bandage lower surface area to facilitate protection of the adhesive and/or hydrocolloid before application of the bandage to the user, for example.

[0009] In some embodiments where the film extends beyond the hydrocolloid region, skin adhesion is enhanced over currently available bandages. In other embodiments where an adhesive layer is attached to the film lower surface area, skin adhesion is also enhanced over currently available bandages. The film and adhesive extension is advantageous at least in eliminating the sticky hydrocolloid edge being outside of the bandage end due to the cold flow of hydrocolloid material. Further, the pressure sensitive adhesive under the film lower surface is advantageous in improving bandage bond to the skin as compared to hydrocolloid material alone. The adhesive secures the bandage end to skin better than a hydrocolloid dressing without such an adhesive coated extension.

[0010] The bandage can be made in a variety of shapes. However, the bandage preferably dimensioned in height, width and depth so as to provide enhanced absorbency, enhanced structural integrity and enhanced adhesion and patient comfort.

[0011] The foregoing and other objects, features, and advantages of the present invention will be apparent from the following detailed description of the preferred embodiments which makes reference to several drawing figures.

### BRIEF DESCRIPTION OF THE DRAWINGS

[0012] FIG. 1 is a perspective view of the components of one embodiment of the bandage

being applied to the skin.

[0013] FIG. 2 is a perspective view of an alternate embodiment of the bandage.

[0014] FIG. 3 is a perspective view of another alternate embodiment of the bandage. [0015] FIG. 4 is a perspective view of another alternate embodiment of the bandage.

[0016] FIG. 5 is a perspective view of the components of one embodiment of the bandage being applied to the skin.

[0017] FIG. 6 is a perspective view of an alternate embodiment of the bandage.

[0018] FIG. 7 is a perspective view of another alternate embodiment of the bandage. [0019] FIG. 8 is a perspective view of another alternate embodiment of the bandage.

[0020] FIG. 9 is a view of the bandage upper surface area and method of applying the bandage.

#### DETAILED DESCRIPTION OF THE PREFERRED EMBODIMENTS

[0021] In the following description of the preferred embodiments reference is made to the accompanying drawings which form the part thereof, and in which are shown by way of illustration of specific embodiments in which the invention can be practiced. It is to be understood that other embodiments can be utilized and structural and functional changes can be made without departing from the scope of the present invention.

#### [0022] HYDROCOLLOID BANDAGE

[0023] The hydrocolloid bandage (bandage 1) is for the treatment and/or protection of a wound when applied to the skin of the user (FIG. 1). As illustrated in FIG. 1, when applied to the user the bandage 1 has a bandage upper surface area 3 facing away from the user's skin and a bandage lower surface area 5 facing toward the user's skin. The bandage 1 is further defined in having a bandage end 7.

[0024] The bandage 1 generally is comprised of a hydrocolloid region 9 having a hydrocolloid upper surface area 11 having a length 13, hydrocolloid lower surface area 15 having a length 17, and a hydrocolloid thickness 19. The hydrocolloid thickness may range from about 3 — 100 mils, and most preferably about 20—65 mils. The hydrocolloid 9 is further defined in having a hydrocolloid end 21 having a length 23, extending at an angle  $\alpha$  between the hydrocolloid lower surface area to the hydrocolloid upper surface area.

[0025] The hydrocolloid 9 is covered by a flexible film layer (film) 25, preferably such that the film 25 extends beyond the hydrocolloid end. The film has a film upper surface area 27 and a film lower surface area 29 constituting a film thickness 31 and a film end 33. Further, the film preferably has an adhesive layer 35 adhered to the film lower surface area. The adhesive layer may be continuous or discontinuous along the film lower surface area. The adhesive layer has an adhesive upper surface area 37 and an adhesive lower surface area 39 constituting an adhesive thickness 41, and an adhesive end 43.

[0026] DESIGN

[0027] The bandage preferably dimensioned in height, width and depth so as to provide enhanced adhesion and patient comfort.

[0028] In one embodiment, the bandage 1 has the following configuration (FIG. 2). The bandage 1 preferably has a hydrocolloid region 9 wherein the hydrocolloid upper surface area 11 and hydrocolloid lower surface area 15 are substantially parallel to one another, and the hydrocolloid thickness 19 is substantially uniform. Further, the hydrocolloid end 21 is preferably substantially perpendicular (about 90°) to the hydrocolloid upper and lower surface areas 11/15. The bandage 1 also preferably has a film 25 formed such that the film 25 covers the hydrocolloid region 9 and extends beyond the hydrocolloid end 21 to form a film end 33. Preferably the film end extends beyond the hydrocolloid end. Thus in this embodiment, the bandage lower surface area 5 is formed from the hydrocolloid lower surface area 15 and the film lower surface area 29 extending beyond the hydrocolloid end 21.

[0029] The bandage may also preferably have an adhesive layer 35 situated between the film lower surface area 29 and the hydrocolloid upper surface area 11 (FIG. 3). The adhesive 35 is preferably formed such that the adhesive 35 covers the hydrocolloid region 9 and extends beyond the hydrocolloid end 21 to form an adhesive end 43. Thus in this embodiment, the bandage lower surface area is formed from the hydrocolloid lower surface area 15 and the adhesive lower surface area 39 extending beyond the hydrocolloid end 21. Alternatively, the adhesive 35 may be present discontinuously on the film lower surface area 29 (FIG. 4).

[0030] In one specific embodiment of the bandage, the dimensions may be as follows. The bandage may be of rectangular shape of about 1—2" wide and about 1.5-3" long measuring from bandage end to end. The film thickness may be about by about 1-2 mils, and the adhesive thickness about 1-3 mils. The hydrocolloid region may have a uniform thickness of about 20-65 mils, wherein the hydrocolloid end is a length of the same 20-65 mils. The film may have a length of about 1—2" wide and about 1.5-3" long, and extend beyond the

hydrocolloid end by about 5mm.

[0031] In an alternate embodiment, the bandage 1 has the following configuration (FIG. 5). The bandage 1 preferably has a hydrocolloid region 9 wherein the hydrocolloid upper surface area 11 and hydrocolloid lower surface area 15 are substantially parallel to one another. Further, the length of the hydrocolloid lower surface area 17 exceeds that of the hydrocolloid upper surface area 13, and the hydrocolloid end is formed at an angle  $\alpha$  of preferably less than about 90° to the hydrocolloid lower surface area 15, and most preferably at an angle  $\alpha$  of about 100 to about 60°. The bandage 1 also preferably has film 25 and adhesive layers 35 formed such that they cover the hydrocolloid region and extend beyond the hydrocolloid end 21.

[0032] In one specific embodiment of the bandage, the dimensions may be as follows. The bandage may be of rectangular shape of about 1—2" wide and about 1.5-3" long measuring from bandage end to end. The film thickness may be about by about 1-2 mils, and the adhesive thickness about 1-3 mils. The hydrocolloid region may have a non-uniform thickness, and at the greatest hydrocolloid thickness be about 20-65 mils, and wherein the hydrocolloid end has a length greater than the greatest hydrocolloid thickness. The ratio of the lower surface area length (17) over the upper surface area length (13) is in a range of 1.1 - 15. The film may have a length of about 1—2" wide and about 1.5-3" long, and extend beyond the hydrocolloid end by about 5mm.

[0033] In another alternate embodiment, the bandage 1 has the following configuration (FIG. 6). The bandage 1 preferably has a hydrocolloid region 9 wherein the hydrocolloid upper surface area 11 and hydrocolloid lower surface area 15 are substantially not parallel to one another. Preferably, the hydrocolloid upper surface area length exceeds 13 that of the hydrocolloid lower surface area length 17, and the hydrocolloid upper surface area 15 extends directly to the lower surface area 11 at an angle  $\alpha$  less than about 30°, preferably at an angle of about 1-10°, and most preferably at an angle of about 1-5°. The bandage also preferably has film 25 and adhesive 35 layers formed such that they cover the hydrocolloid region 9 and extend beyond the hydrocolloid end 21. Thus in this embodiment, the bandage lower surface area 5 is formed from the hydrocolloid lower surface area 15 and the adhesive lower surface area extending beyond the hydrocolloid end 21.

[0034] In one specific embodiment of the bandage, the dimensions may be as follows. The hydrocolloid region may have a non-uniform thickness, and at the greatest hydrocolloid thickness be about 20-65 mils, and wherein the hydrocolloid upper surface area length is



greater than the hydrocolloid lower surface area length. The film may have a length of about 1—2" wide and about 1.5-3" long, and extend beyond the hydrocolloid end by about 5mm.

[0035] In another alternate embodiment, the bandage 1 has the following configuration (FIG. 7). The bandage 1 preferably has a hydrocolloid region 9 wherein the hydrocolloid upper surface area 11 and hydrocolloid lower surface area 15 are substantially parallel to one another. Further, the hydrocolloid end 21 is preferably is not linear (angular or radius of curvature "r") between the hydrocolloid upper 11 and lower 15 surface areas. The bandage 1 also preferably has a film 25 formed such that the film covers the hydrocolloid region 9 and extends beyond the hydrocolloid end. The bandage 1 also preferably has film 25 and adhesive layers 35 formed such that they cover the hydrocolloid region 9 and extend beyond the hydrocolloid end 21.

[0036] In one specific embodiment of the bandage, the dimensions may be as follows. The hydrocolloid region may have a non-uniform thickness, and at the greatest hydrocolloid thickness be about 20-65 mils, and wherein the hydrocolloid upper surface area length is about the same as the hydrocolloid lower surface area length. However, the hydrocolloid end is substantially non-linear having a radius of curvature being about 0.5 -3" or outer diameter (OD) of about 1 -6", most preferably is about 1"—3". The film may have a length of about 1—2" wide and about 1.5-3" long, and extend beyond the hydrocolloid end by about 5mm.

[0037] Alternatively or in addition, the bandage 1 may have an adhesive layer 35 affixed to the hydrocolloid lower surface area 15. Thus in this embodiment, the bandage lower surface area 15 is formed from the adhesive lower surface area 39 only (FIG. 8).

[0038] Flexible Film Layer The film materials which are useful for this invention are not particularly limited as long as they can provide a suitable substrate for the adhesive and/or hydrocolloid and are sufficiently strong to withstand removal from the skin and maintain its integrity, having been secured to the skin by the adhesive and hydrocolloid. Preferably, the backing film layer is water impervious.

[0039] The film is preferably flexible from the viewpoint of comfort. The flexibility is achievable by elasticity in any one or all axes of the material. Further, the film is preferably pliable to accommodate skin contours, when applied to areas of skin having alterations in surface angles. The film is also preferably breathable and conformable.

[0040] As is appreciated by those skilled in the art, the film materials may include, polyolefins (such as low, medium or high density polyethylene homopolymer, polypropylene or polyethylene or copolymers or blends of polypropylene or polyethylene, for example),

ethylene vinyl acrylate, ethylene acrylic acrylate, ethylene methyl acrylate, polyvinyl chloride, polyester, polyurethane, polyamide and copolyester films, or combinations thereof. In one example, a film may include polyurethane and copolyester films having a moisture vapor transmission rate (MVTR) in a range of about 100 to about 5000 g/24 h m<sup>2</sup> (per ASTM E96 desiccant method with upright cup at 37°C). A preferred film has a MVTR of greater than about 500 g/24 h m<sup>2</sup>. Typical examples are Bioflex 125 (polyurethane) and Bioflex 235 (copolyester) available from Scapa Medical, Windsor CT.

[0041] The film layer is also preferably of a thickness to provide sufficient strength to the bandage, but also of a thinness which will be comfortable to the wearer and pliable to contact all skin surfaces. In one embodiment, the film thickness is about 0.5 to about 10 thousands of an inch (mils), and in other embodiments, the film thickness is about 1 to about 5 mils, and most preferably about 1-2 mils. The film may or may not be of a uniform thickness over its length.

[0042] The film layer may be physically perforated to create micro or small openings and holes, which can improve the moisture permeation rate. Such film layer holes may extend from the film upper surface area through the film thickness to the film lower surface area.

[0043] Hydrocolloid Region The hydrocolloid region is comprised of any hydrocolloid composition known or developed by those skilled in the art, preferably having hydrophilic particles capable of swelling in water and transporting water. Hydrophilic particles which may be used in the invention include, but are not limited to naturally derived substances (such as silica, collagen, pectin, gelatin, starches, guar gum, gum arabic, locust bean gum, gum karaya, alginic acid and its sodium or calcium salts) and synthetic substances (such as sodium carboxymethylcellulose (CMC), crosslinked sodium carboxymethylcellulose, crystalline sodium carboxymethyl cellulose, polyvinyl alcohol, polyvinyl pyrrolidone, high molecular weight polyethylene glycols and polypropylene glycols, cross-linked dextran and starch-acrylonitrile graft copolymer, starch sodium polyacrylate, gluten, polymer of methyl vinyl ether and maleic acid and derivatives; polyvinyl pyrrolidone, polyethylene glycols, polypropylene glycols, metal and/or ammonium salts of polyacrylic acid and/or its copolymers, and metal or ammonium salts of polystyrene sulfonic acid) or a variety of alternative commercially available absorbent products.

[0044] Adhesive Layer An adhesive useful in this invention is any substance which has good adhesion with the hydrocolloid region and/or the bandage in contact with the skin. The adhesive layer can be located on any part of, or the entirety of, the film lower surface area.

[0045] A wide range of adhesive materials can be used for the hydrocolloid dressing, and can be selected to maximize adhesion, absorption and comfort, while minimizing irritation to the user. The adhesive layer is preferably efficient at adhering to, but not damaging to the dermis or wound site. The adhesive layer further preferably has a relatively greater adherence to the film than to the dermis or wound site. There can be a desired range of adhesive strength for the adhesive layer in the present invention. The strength can vary relative to the selected use of the bandage.

[0046] The adhesive is preferably comprised of a polymeric adhesive composition. In one preferred embodiment, the polymeric adhesive composition comprises a pressure sensitive polymer mixture. In some embodiments, rubber based, polyacrylate based, urethane based or silicone based pressure sensitive adhesives can be used. Typical adhesives for use in the invention include, but are not limited to those physically or chemically crosslinked by polymer phase separation. Such phase separation is preferably not compromised at below 50°C. A typical pressure sensitive adhesive with good adhesion to skin is an acrylic PSA crosslinked thermally or cured through metal chelating agent such as aluminum acetoacetate.

[0047] The adhesive layer thickness is preferably thick enough to afford suitable adhesion to and absorption from the dermis or wound site. In one embodiment, the adhesive layer thickness is about 0.5 to 8 mils, and in other embodiments, the thickness of the adhesive is about 0.5 to about 4 mils, and preferably about 1 to about 3 mils. The adhesive layer may or may not have a uniform thickness throughout its length.

[0048] Additives. Further, the hydrocolloid and/or adhesive layer can also contain additives, such as tackifiers, plasticizers and/or stabilizers to achieve the desired adhesive properties.

[0049] In some embodiments, the bandage (hydrocolloid and/or adhesive layer) can include therapeutic agents as additives, including those which can assist with wound protection and healing, such as alcohol, peroxide or betadine; antimicrobials; antibacterials, such as Triclosan, or polysporin; antivirals, such as Nonoxyl-9; antifungals, such as imidazole; anti-inflammatories such as hydrocortizone; wound healing promoters, such as growth factors; collagen; moisturizers, such as aloe or vitamins A, D or E; anti-scarring medications such as cortisone or pharmacologically active agents, including, but not limited to, analgesics, anesthetics, anti-inflammatories, and steroids. During processing of the bandage, agents may be combined with either the adhesive composition, with the hydrocolloid, or both, for example. In another example, the active agent may be adhered to at least a portion of the

hydrocolloid or adhesive lower surface area.

[0050] Release Liner A release liner 45 can be applied to the bandage lower surface area 5 to facilitate to protect the adhesive 35 and/or hydrocolloid 9 before application of the bandage to the user, for example. Suitable liner materials include, but are not limited to bleached Kraft paper, silicone coated on one side at least where contact with the hydrocolloid and/or adhesive layer is made.

[0051] The liner can be of the same dimensions as the bandage, or can be of different dimensions to facilitate removal of the liner from the bandage. Where the liner is of different dimensions as the dressing, the liner can be larger in any one or all planar dimensions than the dressing. Further, the liner can have lines of weakness, such as scores or perforations, so as to facilitate removal of the liner from the dressing.

#### [0052] BANDAGE SHAPE

[0053] The bandage can generally be made in a variety of shapes. Examples of the shapes of the bandage include, but are not limited to a triangle, square, rectangle, circle or oval. Such shapes may be suitable for use on different regions of the body (FIG. 9). For example, the bandages are preferably a rectangular bandage about 1" — 2" wide and about 1.5" - 3" long along the bandage periphery. In another example, the bandage is preferably oval being about 1 — 2" wide and 2 — 4" long.

#### [0054] COLOR

[0055] In some embodiments, at least one of the hydrocolloid, film or/and adhesive are substantially transparent or clear, a flesh-like color or shade so as to effectively blend with the skin of wearer, or translucent. In other embodiments, the film is effectively colored or rendered ornate or patterned on its upper surface area.

#### [0056] USING THE BANDAGE

[0057] To use the bandage a user obtains the bandage, removes the liner (if present) to expose the adhesive lower surface area and hydrocolloid lower surface area of the bandage, applying the bandage to the skin, having a wound with the lower surface of the bandage to the skin, such that the adhesive and hydrocolloid lower surface areas are preferably in direct contact with the skin (FIG. 9). The user then leaves the bandage on the wound site a proscribed period of time, such that the bandage absorbs moisture away from the wound, while maintaining adherence to the skin, even at the perimeter of the bandage (film end).

#### [0058] ALTERNATIVES

[0059] The bandage may be designed in alternate ways and remain within the spirit of this

invention.

[0060] In one example, a bandage may be formed having a water absorbent hydrocolloid region with a thickness and an upper surface area and a lower surface area and a hydrocolloid end extending between the upper surface area to the lower surface area. Further, a flexible film layer may be affixed to the hydrocolloid upper surface area having a film thickness, and the film may be formed such that the film extends over the hydrocolloid upper surface area and at least beyond the hydrocolloid end. Optionally the bandage may have a removable liner on the hydrocolloid lower surface area. Preferably this bandage would have a film thickness greater than about  $\frac{1}{4}$  of the sum of the hydrocolloid thickness and the film thickness.

[0061] In a second example, a bandage may be formed having a hydrocolloid region for contacting a wound site, and a flexible film layer covering one side of the hydrocolloid region; and the bandage may include a bandage region extending outwardly beyond the hydrocolloid region at a selected distance of less than 5mm, wherein the bandage region is substantially devoid of hydrocolloid. Preferably a bandage of this type would also include a liner removably attached to a side of the hydrocolloid region opposite from the flexible film layer. The bandage region may extend from the hydrocolloid end for any distance including less than 5mm or more than 5mm.

[0062] In a third example, the bandage may have wells or dimples formed in any one of or all of the film, adhesive or hydrocolloid thickness, such that the thickness has areas of greater and lesser thickness. Further, the bandage may have internal voids, such that any one of the layer surface areas is not in direct apposition to the surface of another. For example, a void may be created between the film layer and the hydrocolloid such that the film lower surface area is not in direct contact with the hydrocolloid upper surface area at some points over the length of the bandage. Alternatively, an internal void may be created in the hydrocolloid thickness, such that between the hydrocolloid upper surface area and lower surface area, there is a region of the hydrocolloid thickness devoid of hydrocolloid.

## WHAT IS CLAIMED IS:

1. A hydrocolloid bandage for use on a wound site comprising at least:
  - a hydrocolloid region, wherein the hydrocolloid region has a hydrocolloid upper surface area having an upper surface area length and a hydrocolloid lower surface area having a lower surface area length, and wherein the hydrocolloid region has a hydrocolloid end extending for an end length between the hydrocolloid upper surface area and the hydrocolloid lower surface area; and
  - a film layer adhered to the hydrocolloid upper surface area and hydrocolloid end length, the film layer having a film length and a film lower surface area, wherein the film layer has a film length which exceeds the upper surface area length and hydrocolloid end length, and wherein the film layer extends beyond the hydrocolloid end such that a bandage lower surface area is formed by the hydrocolloid lower surface area and the film lower surface area extending beyond the hydrocolloid end to a film end.
  
2. A hydrocolloid bandage for use on a wound site comprising at least:
  - a hydrocolloid region, wherein the hydrocolloid region has a hydrocolloid upper surface area having an upper surface area length and a hydrocolloid lower surface area having a lower surface area length, and wherein the hydrocolloid region has a hydrocolloid end extending for an end length between the hydrocolloid upper surface area and the hydrocolloid lower surface area; and
  - an adhesive layer film layer adhered to the hydrocolloid upper surface area and hydrocolloid end length having an adhesive layer length and an adhesive layer upper surface area, wherein the adhesive layer length exceeds the upper surface area length and hydrocolloid end length, and wherein the adhesive layer extends beyond the hydrocolloid end such that a bandage lower surface area is formed by the hydrocolloid lower surface area and the adhesive lower surface area extending beyond the hydrocolloid end to an adhesive end; and
  - a film layer adhered to the adhesive layer upper surface area.
  
3. The hydrocolloid bandage of claim 1, wherein the bandage further comprises an adhesive layer adhered to the bandage lower surface area.
  
4. The hydrocolloid bandage of claim 1, 2 or 3, wherein the hydrocolloid upper

surface area and the hydrocolloid lower surface area are substantially parallel, and wherein the hydrocolloid end is at an angle substantially perpendicular to the hydrocolloid upper and lower surface areas.

5. The hydrocolloid bandage of claim 4, wherein the hydrocolloid upper surface area and the hydrocolloid lower surface area are substantially parallel, and wherein the hydrocolloid end is linear.

6. The hydrocolloid bandage of claim 4, wherein the hydrocolloid upper surface area and the hydrocolloid lower surface area are substantially parallel, and wherein the hydrocolloid end has a radius of curvature of 1"- 3".

7. The hydrocolloid bandage of claim 1, 2 or 3, wherein the hydrocolloid upper surface area and the hydrocolloid lower surface area are substantially parallel, and wherein the hydrocolloid lower surface area length exceeds the hydrocolloid upper surface area length, and wherein the hydrocolloid end is at an angle of less than about 90° to the hydrocolloid lower surface area.

8. A hydrocolloid bandage for use on a wound site comprising at least:

a hydrocolloid region, wherein the hydrocolloid region has a hydrocolloid upper surface area having an upper surface area length and a hydrocolloid lower surface area having a lower surface area length, and wherein the hydrocolloid region has a hydrocolloid end between the hydrocolloid upper surface area and the hydrocolloid lower surface area;

the hydrocolloid region having the hydrocolloid upper surface area and hydrocolloid lower surface area are substantially not parallel to one another, and further wherein the hydrocolloid upper surface area length exceeds that of the hydrocolloid lower surface area length, and wherein the hydrocolloid upper surface area extends directly to the lower surface area at an angle of less than about 60°; and

a film layer adhered to the hydrocolloid upper surface area, the film layer having a film length and a film lower surface area, wherein the film layer has a film

length which exceeds that of the upper surface area length, and wherein the film layer extends beyond the upper surface area length.

9. The hydrocolloid bandage of claim 1 or 2 wherein the film layer extends from the hydrocolloid end for a distance of about 5 mm.
10. A hydrocolloid bandage of claim 1, wherein the adhesive layer is about 0.5 to about 8 mils.
11. A hydrocolloid bandage of claim 1, wherein the film layer is about 0.5 to about 10 mils.
12. A hydrocolloid bandage of claim 1, further comprising a release liner adhered to the bandage lower surface area.
13. A hydrocolloid bandage of claim 1, wherein at least one of the adhesive layer, film layer, or hydrocolloid region are substantially transparent or clear.
14. A hydrocolloid bandage of claim 1, wherein at least one of the adhesive layer, film layer, or hydrocolloid region are substantially flesh colored.
15. A method of using the hydrocolloid bandage of claim 1 comprising obtaining the bandage and applying the bandage lower surface area to a user's skin or wound site.
16. A bandage comprising a water absorbent hydrocolloid region having a thickness and an upper surface area and a lower surface area and a hydrocolloid end extending between the upper surface area to the lower surface area,  
a flexible film layer affixed to the hydrocolloid upper surface area having affixed, wherein the flexible film layer has a film thickness and the film is formed such that the film extends over the hydrocolloid upper surface area and at least beyond the hydrocolloid end; and  
optionally a removable liner on the hydrocolloid lower surface area.
17. A bandage of claim 16, wherein the film thickness is greater than  $\frac{1}{4}$  of the



sum of the hydrocolloid thickness and the film thickness.

18. A bandage comprising a hydrocolloid region for contacting a wound site, and a flexible film layer covering one side of the hydrocolloid region; and including a bandage region extending outwardly beyond the hydrocolloid region at a selected distance, of less than about 5mm, the bandage region being devoid of hydrocolloid.

19. A bandage of claim 18, further comprising a liner removably attached to a side of the hydrocolloid region opposite from the flexible film layer.

20. A bandage of claim 18, wherein the selected distance is less than about 5mm.

21. A bandage of claim 18, wherein the selected distance is greater than about 5mm.

1/4

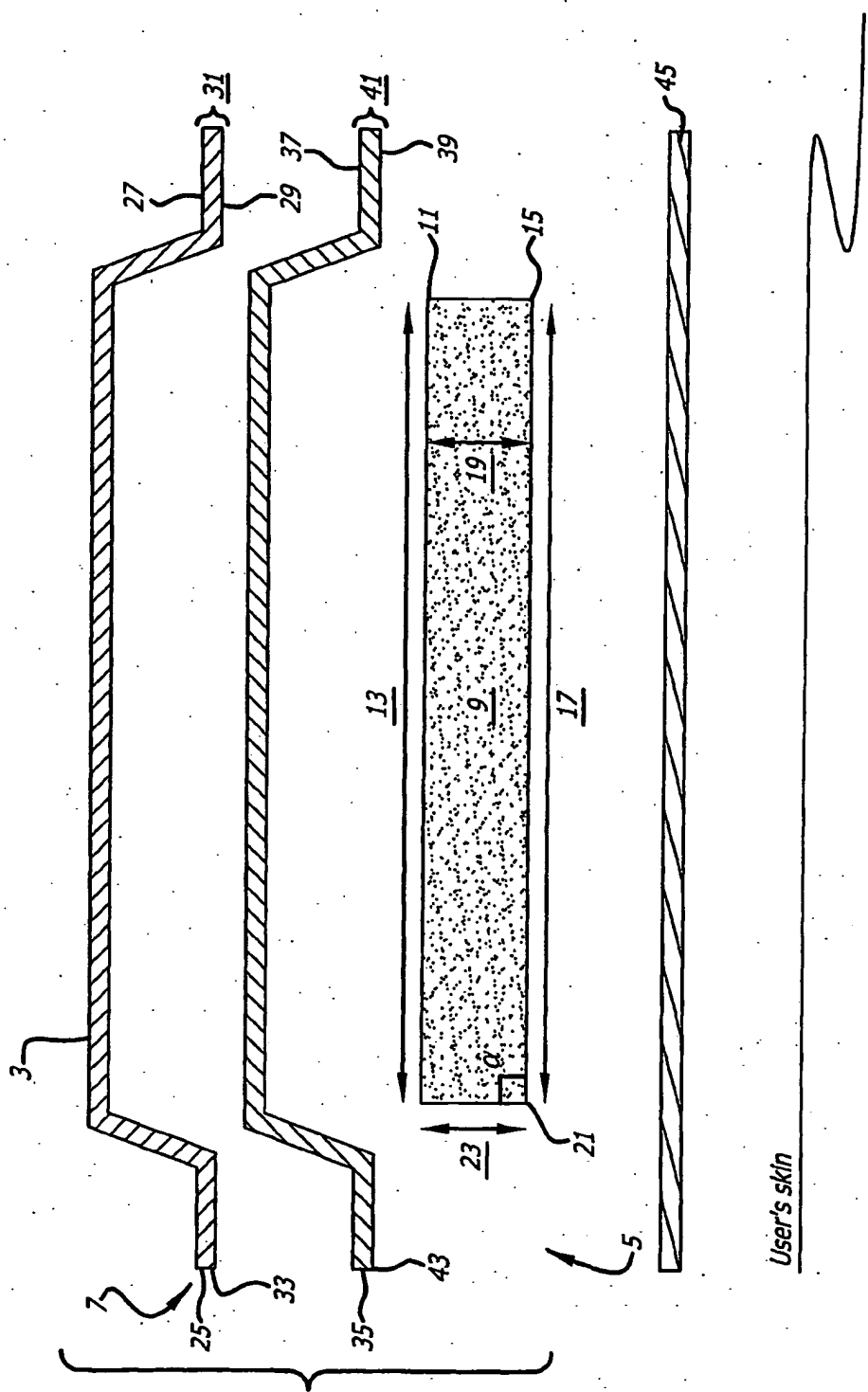

FIG. 1

FIG. 2

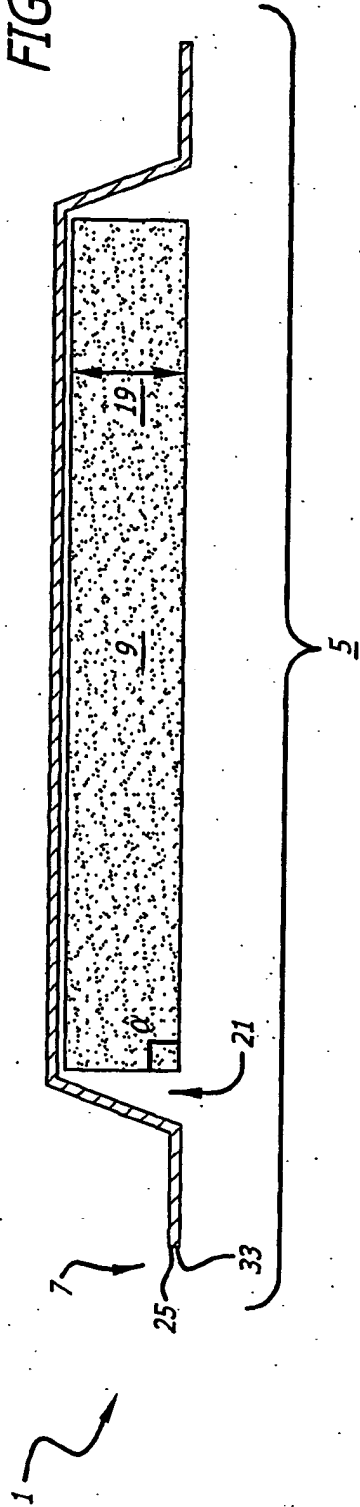

FIG. 3

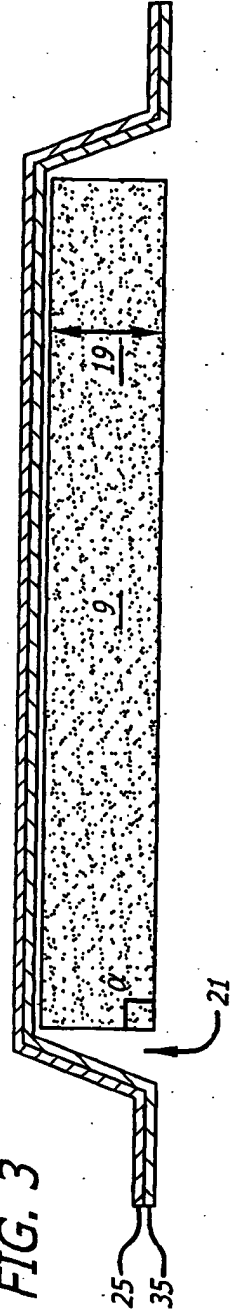
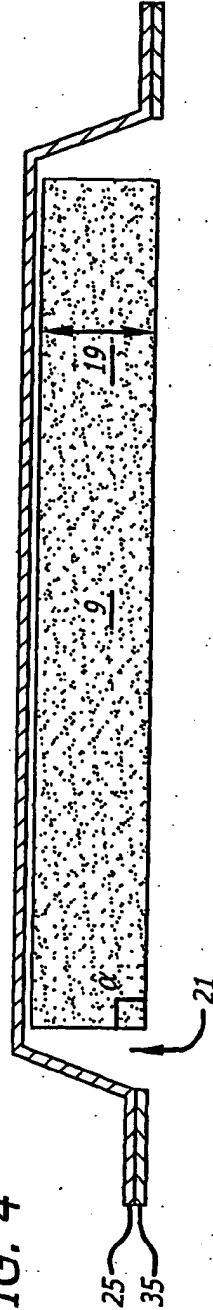

FIG. 4



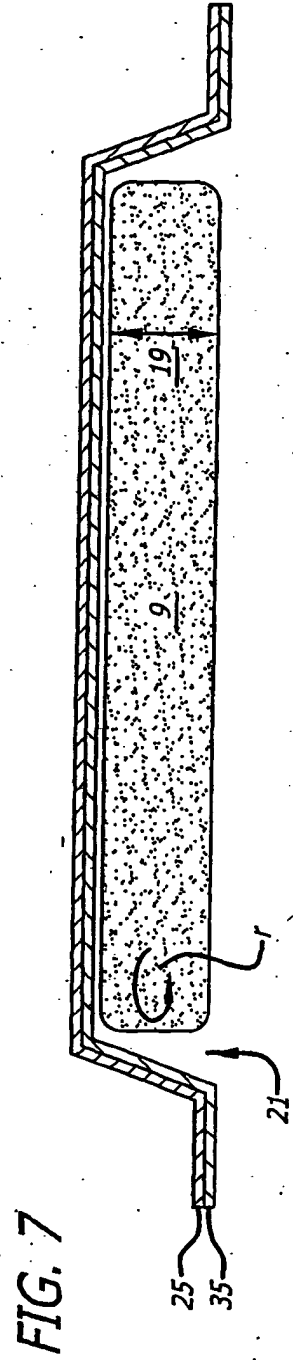
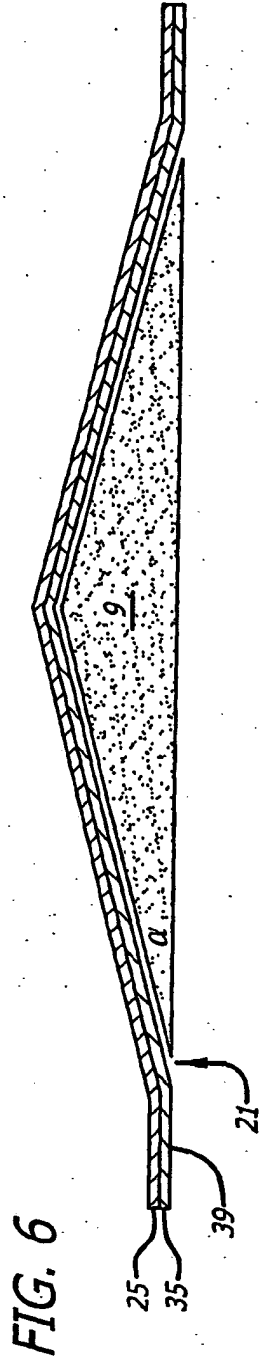
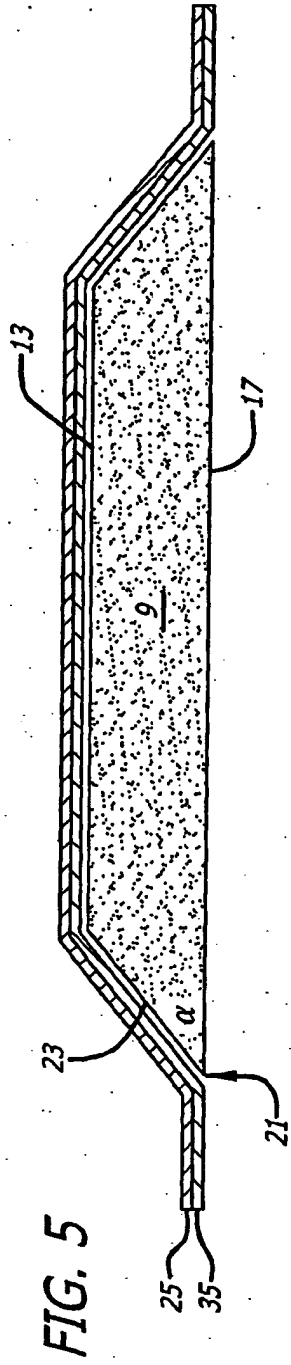

FIG. 8

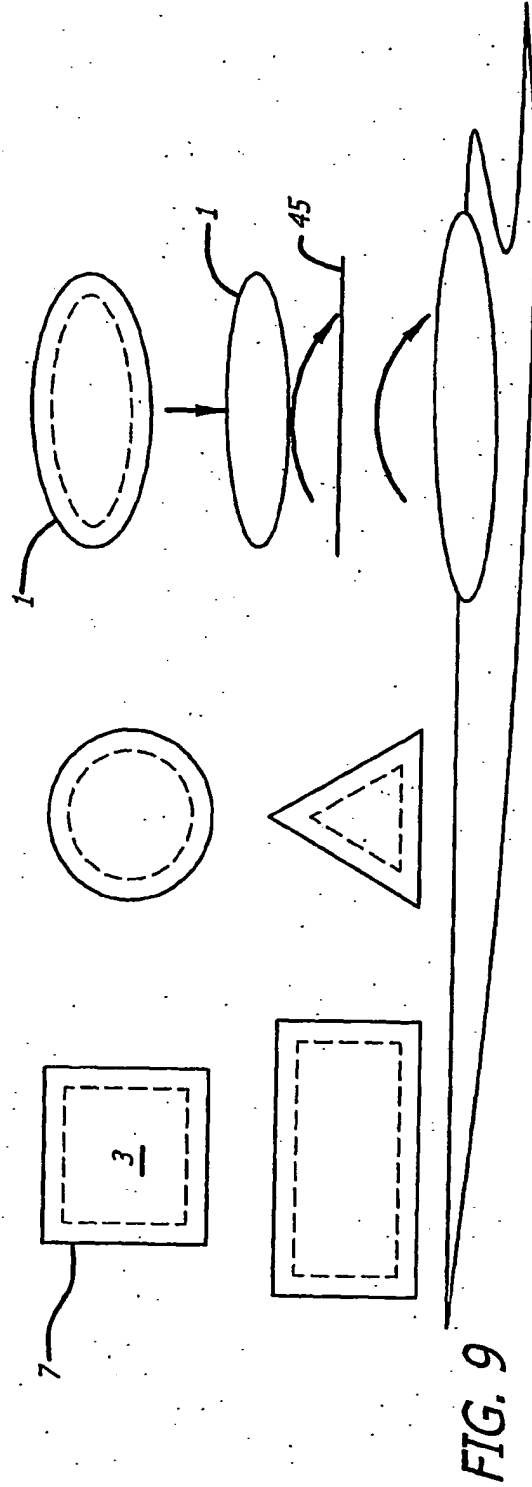
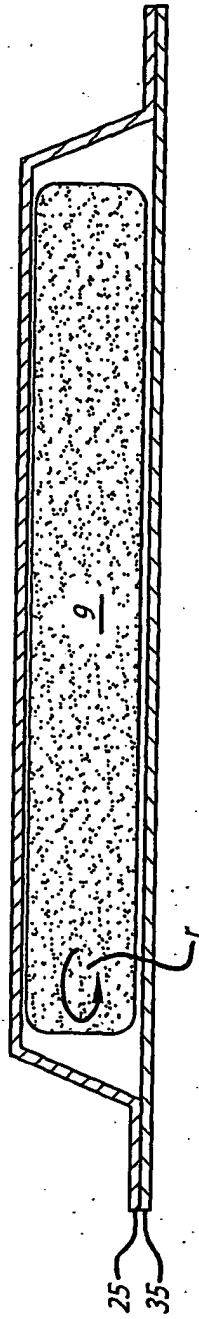

FIG. 9

## INTERNATIONAL SEARCH REPORT

International Application No

PCT/US 02/41745

A. CLASSIFICATION OF SUBJECT MATTER  
 IPC 7 A61F13/02 A61L15/22 A61L15/60

According to International Patent Classification (IPC) or to both national classification and IPC

## B. FIELDS SEARCHED

Minimum documentation searched (classification system followed by classification symbols)

IPC 7 A61F A61L

Documentation searched other than minimum documentation to the extent that such documents are included in the fields searched

Electronic data base consulted during the international search (name of data base and, where practical, search terms used)

EPO-Internal, WPI Data, PAJ

## C. DOCUMENTS CONSIDERED TO BE RELEVANT

Category *	Citation of document, with indication, where appropriate, of the relevant passages	Relevant to claim No.
X	EP 0 591 898 A (MINNESOTA MINING & MFG) 13 April 1994 (1994-04-13) page 2, line 1 - line 4 - <i>pressure sensitive</i> page 6, line 3 - line 16 <i>adhesive</i>	1-21
X	EP 0 617 938 A (SQUIBB BRISTOL MYERS CO) 5 October 1994 (1994-10-05) page 4, line 3 - page 5, line 5 - <i>see US 6,066,773</i> figures <i>US 5,681,579</i>	1-21
X	EP 0 536 875 A (NDM ACQUISITION CORP) 14 April 1993 (1993-04-14) abstract figures <i>handyc - includes support layer</i> <i>-/-</i>	1-21

Further documents are listed in the continuation of box C.

Patent family members are listed in annex.

## \* Special categories of cited documents:

- \*A\* document defining the general state of the art which is not considered to be of particular relevance
- \*E\* earlier document but published on or after the international filing date
- \*L\* document which may throw doubts on priority claim(s) or which is cited to establish the publication date of another citation or other special reason (as specified)
- \*O\* document referring to an oral disclosure, use, exhibition or other means
- \*P\* document published prior to the international filing date but later than the priority date claimed

- \*T\* later document published after the international filing date or priority date and not in conflict with the application but cited to understand the principle or theory underlying the invention.
- \*X\* document of particular relevance; the claimed invention cannot be considered novel or cannot be considered to involve an inventive step when the document is taken alone.
- \*Y\* document of particular relevance; the claimed invention cannot be considered to involve an inventive step when the document is combined with one or more other such documents, such combination being obvious to a person skilled in the art.
- \*Z\* document member of the same patent family

Date of the actual completion of the international search

22 May 2003

Date of mailing of the international search report

30/05/2003

Name and mailing address of the ISA

European Patent Office, P.B. 5818 Patentlaan 2  
 NL - 2280 HV Rijswijk  
 Tel. (+31-70) 340-2040, Tx. 31 651 epo nl,  
 Fax (+31-70) 340-3016

Authorized officer

Muñoz, M

INTERNATIONAL SEARCH REPORT

International Application No

PCT/US 02/41745

C.(Continuation) DOCUMENTS CONSIDERED TO BE RELEVANT

Category °	Citation of document, with indication, where appropriate, of the relevant passages	Relevant to claim No.
P, X	WO 02 10245 A (HUNTSMAN INTERNAT LLC ;LOCKWOOD ROBERT J (US)) 7 February 2002 (2002-02-07) page 4, paragraph 2 -page 5, paragraph 1 page 9, paragraph 1 - last paragraph figures  -----  - from composition	1,2,4,5, 16

# INTERNATIONAL SEARCH REPORT

International application No.  
PCT/US 02/41745

## Box I Observations where certain claims were found unsearchable (Continuation of Item 1 of first sheet)

This International Search Report has not been established in respect of certain claims under Article 17(2)(a) for the following reasons:

1.  Claims Nos.:  
because they relate to subject matter not required to be searched by this Authority, namely:  
  
Although claims 15 are directed to a method of treatment of the human/animal body, the search has been carried out and based on the alleged effects of the compound/composition.
2.  Claims Nos.:  
because they relate to parts of the International Application that do not comply with the prescribed requirements to such an extent that no meaningful International Search can be carried out, specifically:
3.  Claims Nos.:  
because they are dependent claims and are not drafted in accordance with the second and third sentences of Rule 6.4(a).

## Box II Observations where unity of invention is lacking (Continuation of Item 2 of first sheet)

This International Searching Authority found multiple inventions in this International application, as follows:

1.  As all required additional search fees were timely paid by the applicant, this International Search Report covers all searchable claims.
2.  As all searchable claims could be searched without effort justifying an additional fee, this Authority did not invite payment of any additional fee.
3.  As only some of the required additional search fees were timely paid by the applicant, this International Search Report covers only those claims for which fees were paid, specifically claims Nos.:
4.  No required additional search fees were timely paid by the applicant. Consequently, this International Search Report is restricted to the invention first mentioned in the claims; it is covered by claims Nos.:

Remark on Protest

- The additional search fees were accompanied by the applicant's protest.
- No protest accompanied the payment of additional search fees.



## INTERNATIONAL SEARCH REPORT

Information on patent family members

International Application No

PCT/US 02/41745

Patent document cited in search report	Publication date	Patent family member(s)	Publication date	
EP 0591898	A	13-04-1994	CA 2104046 A1	06-04-1994
			DE 69325066 D1	01-07-1999
			DE 69325066 T2	14-10-1999
			DK 591898 T3	29-11-1999
			EP 0591898 A1	13-04-1994
			JP 6200231 A	19-07-1994
			US 5622711 A	22-04-1997
			US 5633010 A	27-05-1997
			EP 0617938	A
AU 666066 B2	25-01-1996			
AU 5793094 A	29-09-1994			
CA 2119489 A1	23-09-1994			
CN 1095916 A, B	07-12-1994			
DE 69412319 D1	17-09-1998			
DE 69412319 T2	04-03-1999			
DK 617938 T3	17-05-1999			
EP 0617938 A1	05-10-1994			
ES 2119062 T3	01-10-1998			
JP 7000444 A	06-01-1995			
US 5681579 A	28-10-1997			
US 6066773 A	23-05-2000			
ZA 9401472 A	27-09-1994			
EP 0536875	A	14-04-1993		
			AT 224207 T	15-10-2002
			AU 641322 B2	16-09-1993
			AU 1945792 A	11-02-1993
			CA 2073274 A1	08-02-1993
			DE 69232777 D1	24-10-2002
			EP 0536875 A1	14-04-1993
			JP 1998476 C	08-12-1995
			JP 5184621 A	27-07-1993
			JP 7034812 B	19-04-1995
			NZ 243404 A	26-08-1994
			ZA 9204900 A	28-04-1993
			WO 0210245	A
EP 1309642 A1	14-05-2003			
WO 0210245 A1	07-02-2002			
US 2002040072 A1	04-04-2002			